



STEELER

SOKÓŁKA

www.steeler.pl

MITSUBISHI OUTLANDER



INSTRUKCJA MONTAŻU

(Orurowania przednie niskie)

OT-R0060 / OTN-R0060







OT-R0060-03 / OTN-R0060-03

OT-R0060-04 / OTN-R0060-04

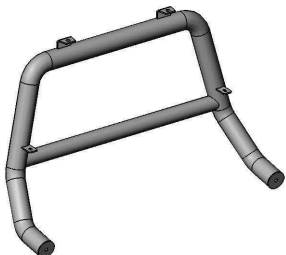
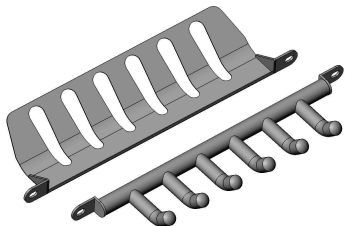
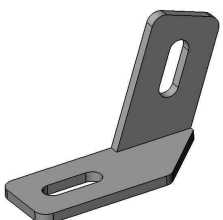
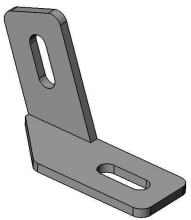

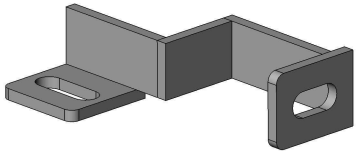
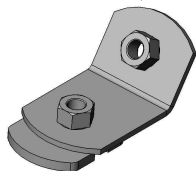
Orurowania z homologacją „e”

Wykaz elementów orurowania:

<p>1. Rura przednia (szt. 1)</p> 	<p>2. Blacha dolna / grill (szt.1)</p> 	
<p>3. Zamocowanie górne I lewe (szt. 1)</p> 	<p>4. Zamocowanie górne I prawe (szt. 1)</p> 	<p>5. Zamocowanie górne II (szt. 2)</p> 
<p>6. Zamocowanie dolne I lewe (szt. 1)</p> 	<p>7. Zamocowanie dolne II prawe (szt. 1)</p> 	<p>8. Zamocowanie dolne III (szt. 1)</p> 
<p>9. Zamocowanie dolne IV (szt. 1)</p> 	<p>10. Pierścień mocujący (szt. 1)</p> 	<p>11. Dekiel z pierścieniem mocującym (szt.1)</p> 

Wykaz elementów łącznych:

Śruby:

M8x35- szt.6
M10x35- szt.4
M10x45- szt.2

Podkładki:

Ø 8,4- szt.8
Ø 8,5- szt.2 (powiększona)
Ø 11- szt.9 (powiększona)

Nakrętki:

M8- szt.4
M10- szt.2



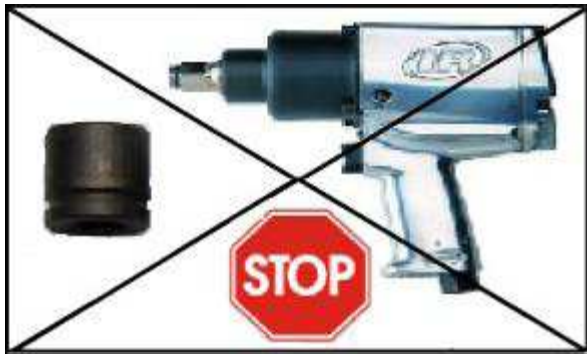

Czas montażu



1 h

UWAGA: *Folię usunąć dopiero po montażu!*

Montaż orurowania (standard):
OT-R0060-03

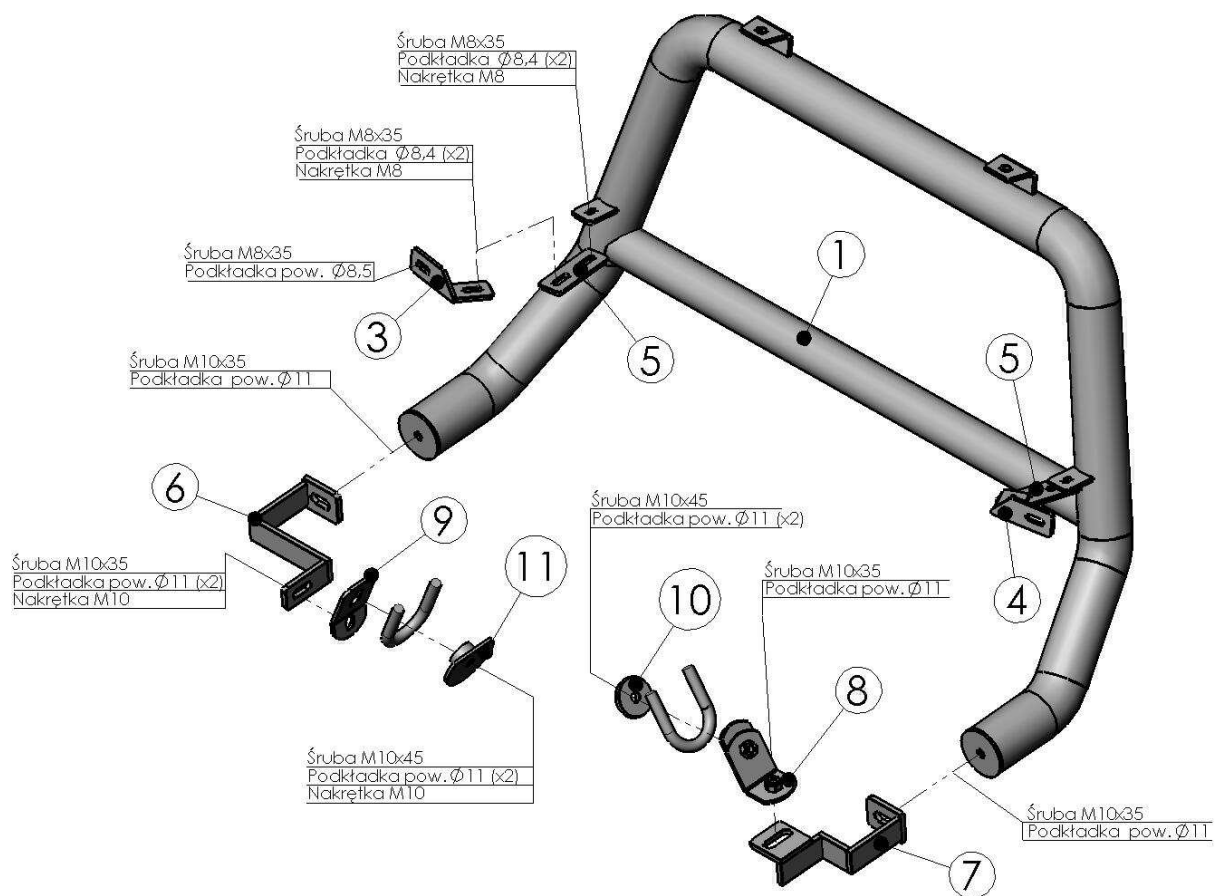

Montaż orurowania z grillem:

OT-R0060

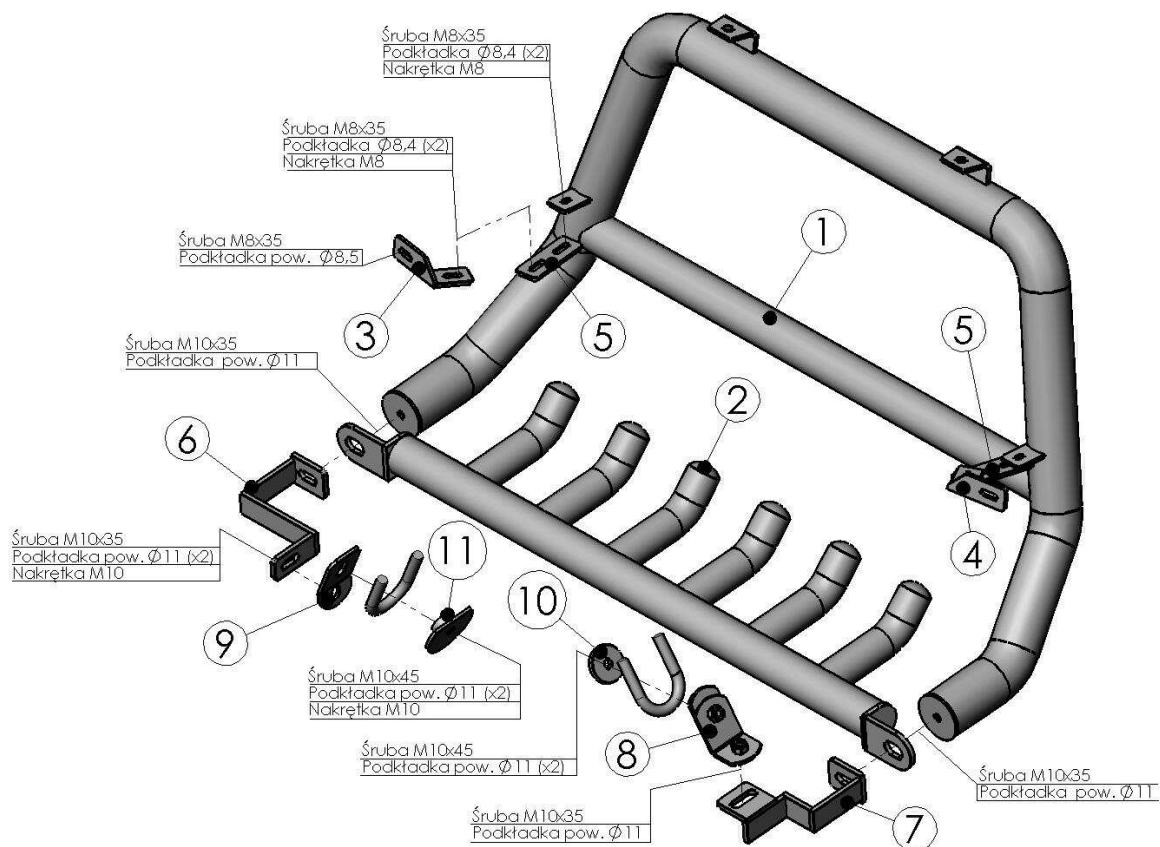

Montaż orurowania z blachą:

OT-R0060-04

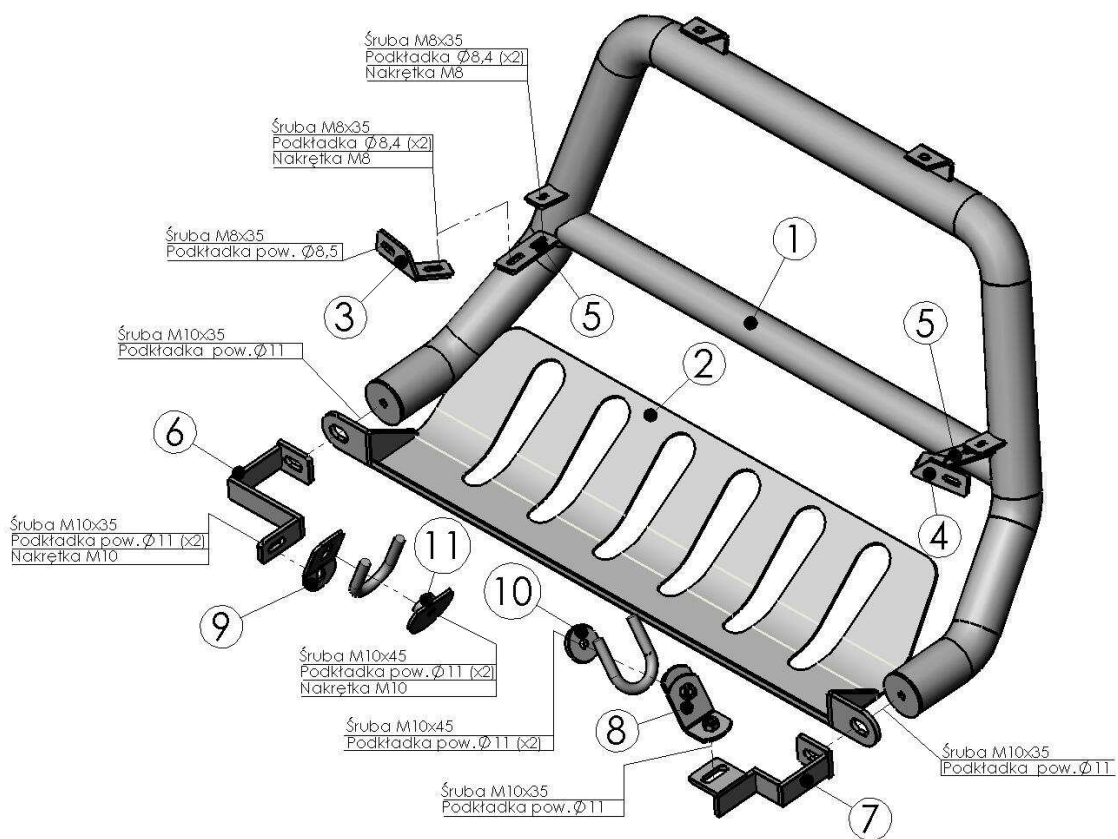

Lewa, górna część orurowania:

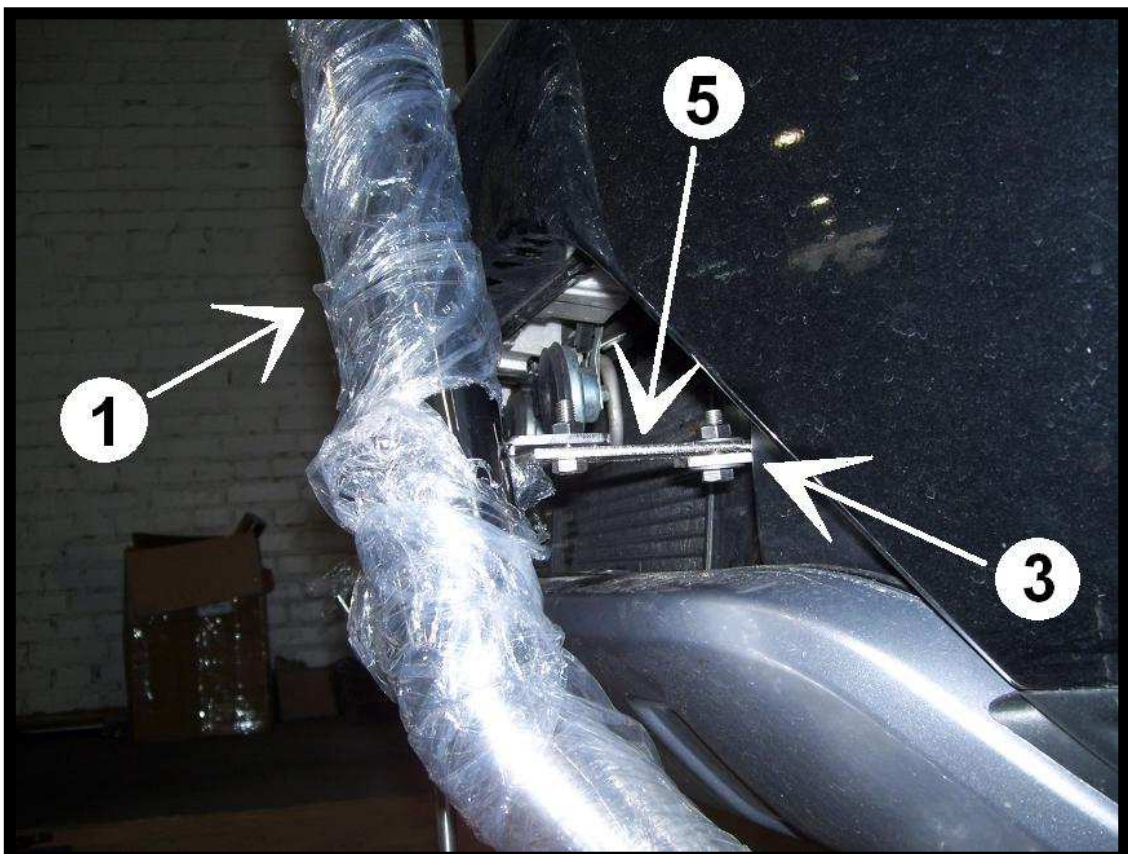

Prawa, górna część orurowania:

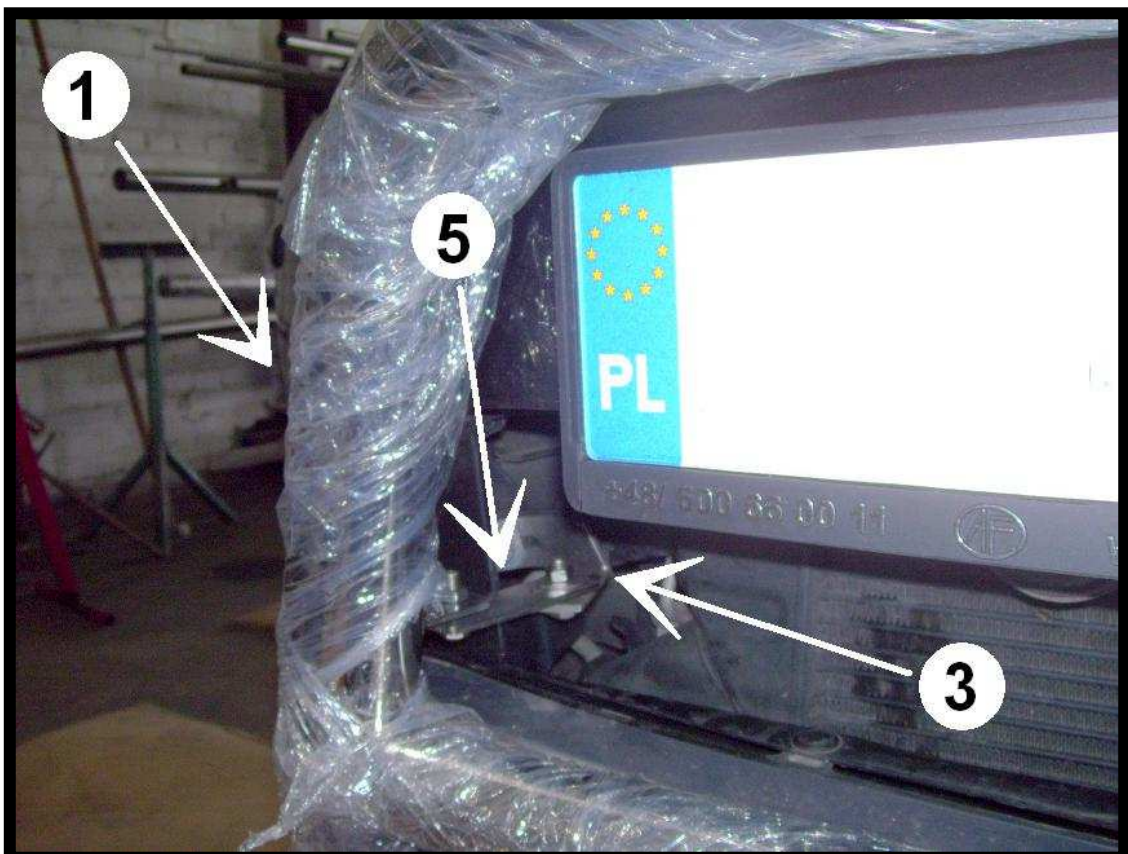
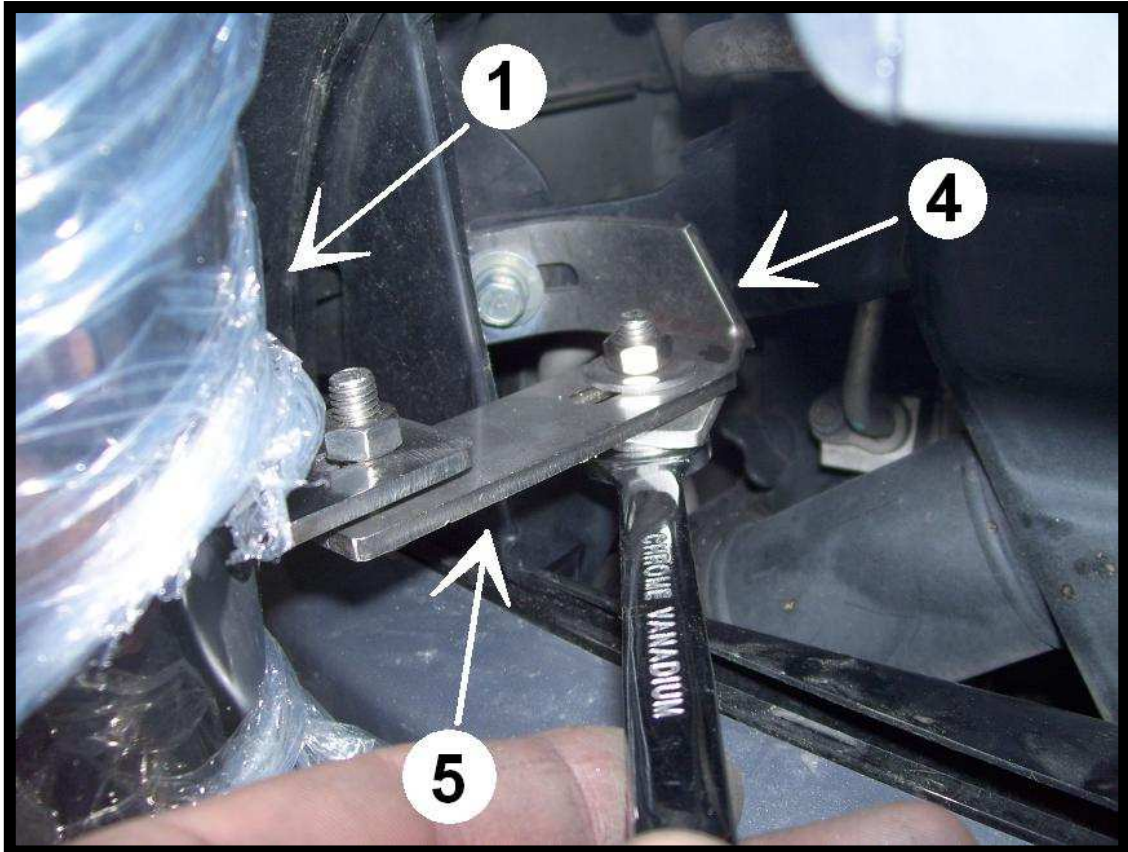

Prawa, dolna część orurowania:

